

Note: Full length studs are not required next to the damper if the spacing from the damper to the full length stud does not exceed the maximum stud spacing. The opening may be framed with studs that are attached to full length studs.

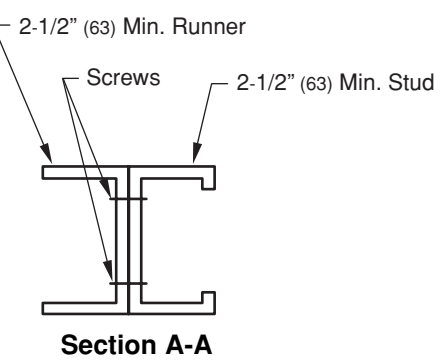

Double stud not required on Penetrations.
120" x 80" (3048 x 2032) or smaller

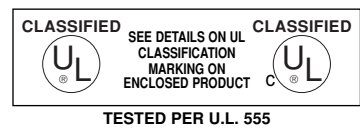

Opening Preparation Detail

NOTES

- Gypsum panels must be screwed 12" (305) O.C. maximum to all stud and runner flanges surrounding opening.
- Mounting angles shall be a minimum of 3/4" x 1-1/2" tall x 20 gauge (19 x 38 x 1.0). For opening sizes ≤ 80" wide (2032), 96" high (2438), and not exceeding 26.67 square feet in area retaining angles are only required on one side of the partition and must be attached to the sleeve and the partition. For larger openings (or optional on smaller openings), 1-1/2" x 1-1/2" x 16 gauge (38 x 38 x 1.5). retaining angles are required on both sides of the partition and must be attached to the sleeve. Attachment to the sleeve shall be with No. 10 (M5) screws or bolts, 3/16" (4.8) diameter steel rivets, Quick-Lock joints or welds, at 12" (305) o.c. maximum. Attachment to partition/opening shall be with min. #10 fasteners with a minimum length as follows: For metal stud and the angles under the drywall, the fasteners must be a min. 1/2" long. For metal stud and the angles over the drywall the fastener must be a min. 1/2" longer than the thickness of the drywall. i.e. if the partition has one layer of 5/8" drywall on the attachment side, the screws must be 1/2" + 5/8" = 1-3/8" long. The fasteners in the partition should be located such that they are 1/2" below the top of the 1-1/2" flange of the retaining angles. Fasteners in the partition should be spaced 12" o.c. max. A minimum of two connections per side, top and bottom. A minimum 3/4" x 20 gauge (19 x 1) flange termination may be used in lieu of mounting angles. Refer to Sleeve Termination Supplemental Installation Instructions and Framing for Fire Dampers for further details. Ensure that attachment device does not interfere with the operation of the damper and the free movement of the damper blades.
- See standard damper installation instruction sheets for additional details.
- For dampers larger than 120" x 80" (3048 x 2032) double vertical studs are required.

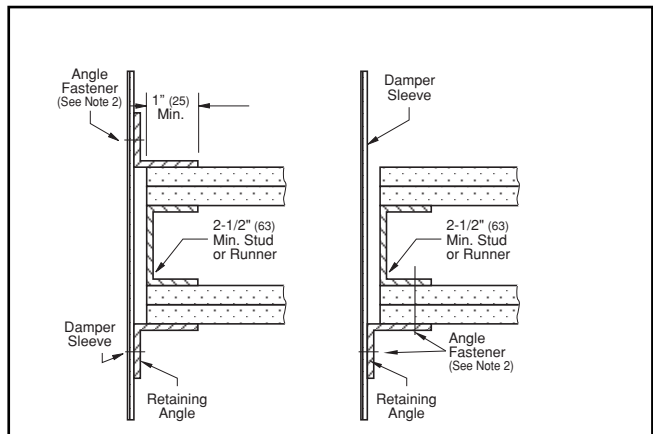

Wall with Two Layers of Drywall

For Openings ≤ 80" x 48"(2032x1218)
40" x 96"(1016x2438)

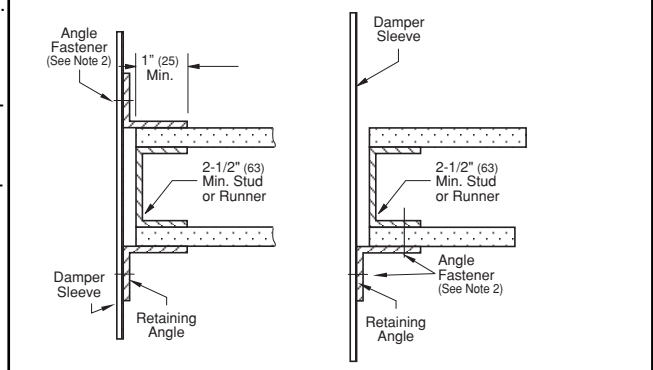

Wall with Single Layer of Drywall

For Openings ≤ 80" x 48"(2032x1218)
40" x 96"(1016x2438)

Fire and Fire Smoke Dampers IIMS July 2008