

The following installation details apply to models **CFD-15, CFD-15LP, CFD-15R, CFD-15SB** and **CFD-20**

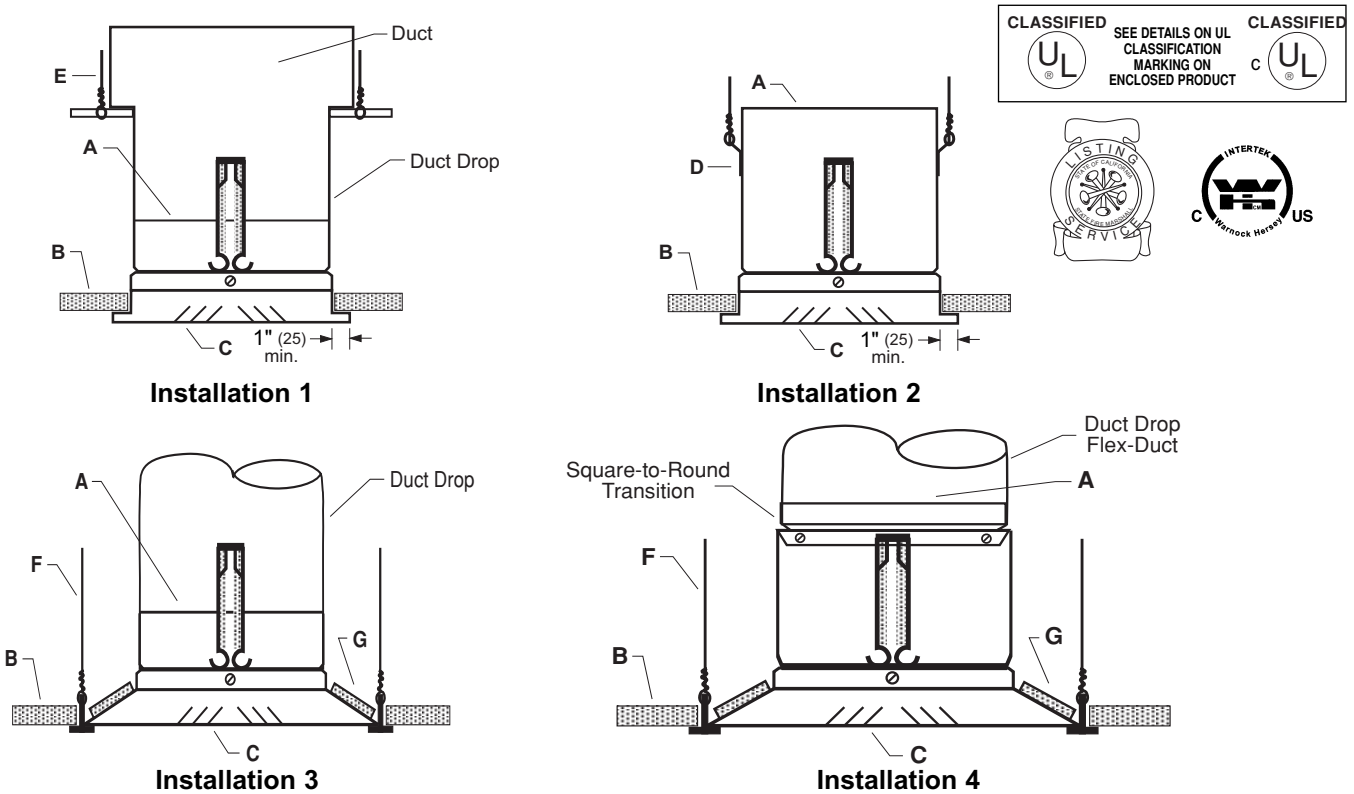

Illustrations show **CFD-15** type damper, model **CFD-20** similar.

- A. The ceiling damper shall be attached to a minimum 22 gauge (0.85) steel sleeve / duct drop by welding, or with rivets, or with #10 (M5) sheet metal screws, or with quick lock, or bolted with 1/4" (6) - 20 bolts at 6" (152) o.c. maximum. A minimum of two connections per side, caution must be taken to ensure that the fasteners do not interfere with the closing of the damper blades. Once the damper has been installed properly, the damper blade(s) should be affixed in the open position. For dampers with (2) blades, open the blades so that they are back-to-back. One of the blades will have a fusible link on the tab on the back of the blade. Slip the fusible link over the tab on the opposite side. For dampers with (1) blade, open the blade and rotate the fuse link holder (located on the damper frame behind the open blade) to the full upright position. Slip the fusible link, on the back of the blade, onto the tab of the fuse link holder. Steel duct drop is not required when flexible duct is utilized in conjunction with a square-to-round transition. Damper requires no additional fire protective material on sleeve when the damper center line is no more than 3" (76) above rated ceiling.
- B. Ceiling penetration should be located within ceiling tiles or panels without necessitating cuts in the ceiling suspension main runners or cross tees. If required, a maximum of one runner or cross tee may be cut to enable proper damper location and installation. Each cut end shall be supported by a minimum 12 swg (2.7) hanger wire.
- C. Sleeve termination shall be a minimum 3/4" (19) flange, 5/8" (16) plaster ground, or "raw". "Raw" termination requires a steel diffuser with minimum 1" (25) flange to be attached to the damper using #8 (M4) sheet metal screws, 3/16" (5) rivets, welds or bolts at 6" (152) o.c. maximum - minimum of 2 connections per side -.
- D. Damper hanger tabs shall be minimum 1" x 2" x 22 gauge (25 x 51 x 0.85) steel, 1 each side minimum, 2 sides minimum. Hanger tabs shall be attached to structural ceiling support with a minimum 12 swg (2.7) wire.
- E. Support duct work with two 1-1/2" x 1/2" x 16 gauge (38 x 13 x 1.6) steel channels. Position the support channels at the bottom of the duct adjacent to both sides of the duct drop and attach to structural ceiling support with a minimum 12 swg (2.7) wire.
- F. T-Bar ceiling grid must be supported on the four corners surrounding the damper by minimum 12 swg (2.7) wire.
- G. Supplemental ceramic refractory thermal blanket 1/10" (2.5) thick x 8 lb density (128 kg/m3) for use where ceiling opening is larger than nominal damper size. The blanket shall be cut so that it protects the back of the diffuser or outlet box up to the base of the fire damper frame.

**Underwriter's Laboratories File #R14603.**  
**The product is also listed by CSFM File # 3226-0368:104**  
**Warnock Hersey File # WHI-495-PSH-0177,-0178**

The following installation details apply to models **CFD-15, CFD-15LP, CFD-15R, CFD-15SB** and **CFD-20**

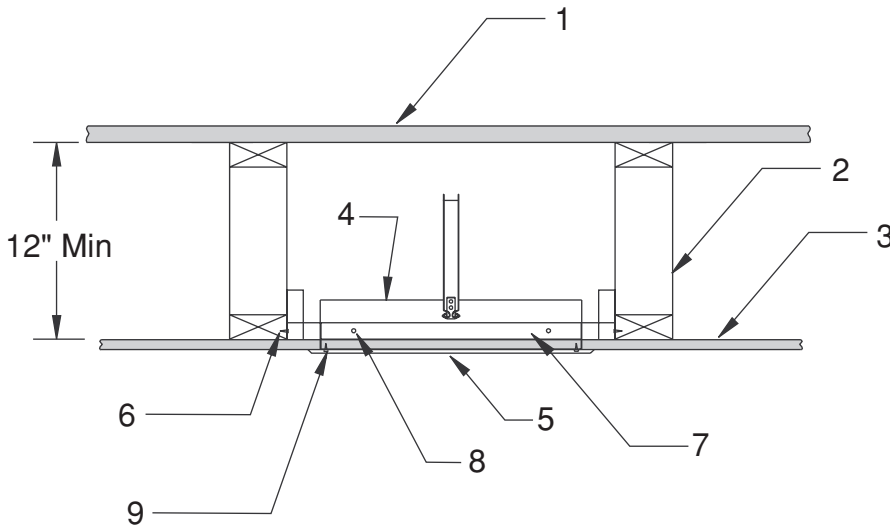

Warnock Hersey Listed  
WHI-495-PSH-0177,-0178



CSFM File # 3226-0368:104

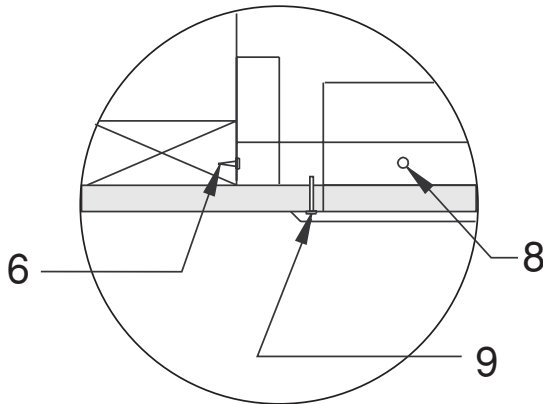

ITEM:	DESCRIPTION
1	Roof/Floor Construction
2	Wood Framing Member or Joist
3	5/8" Gypsum Wallboard
4	Damper
5	Grille (Steel or Aluminum)
6	#6 Penny Nail or #8 Screw
7	1" x 1/2" 20 Gauge Galv. Mounting Angle
8	#8 Tek Screw
9	ø <sup>3/16</sup> Steel Rivet or Screw

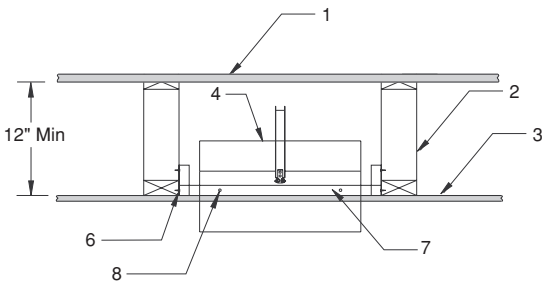

**Damper with Extended Sleeve**

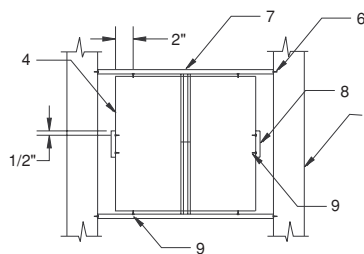

**Top View of Rectangular Damper**

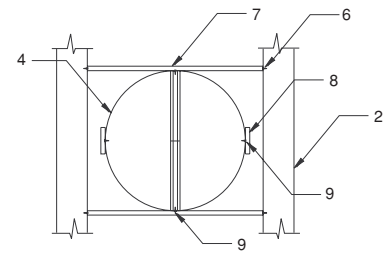

**Top View of Round Damper**

Illustrations show CFD-15 type damper, model CFD-20 similar.

- Measure the actual spacing between the wood framing members and cut the mounting angle to that length plus six inches. Two mounting angles are required. Fold up approximately three inches at 90° at both ends of the mounting angle and attach it to the wood frame with minimum of two each #6 penny nails or #8 screws.
- The damper is attached to the mounting angle by sheet metal screws starting at two inches from the end of the damper. A minimum of two screws per angle is required for rectangular dampers. A minimum of one screw per angle is required for round dampers.
- On the sides opposite the retaining angles, a three inch long mounting angle is required. A minimum of two screws per angle is required. Bottom leg of mounting angle should rest on the ceiling material.